

Sparklike®



SPARKLIKE HANDHELD NOVA™

Gas fill analyzer for insulating glass units
Instructions manual

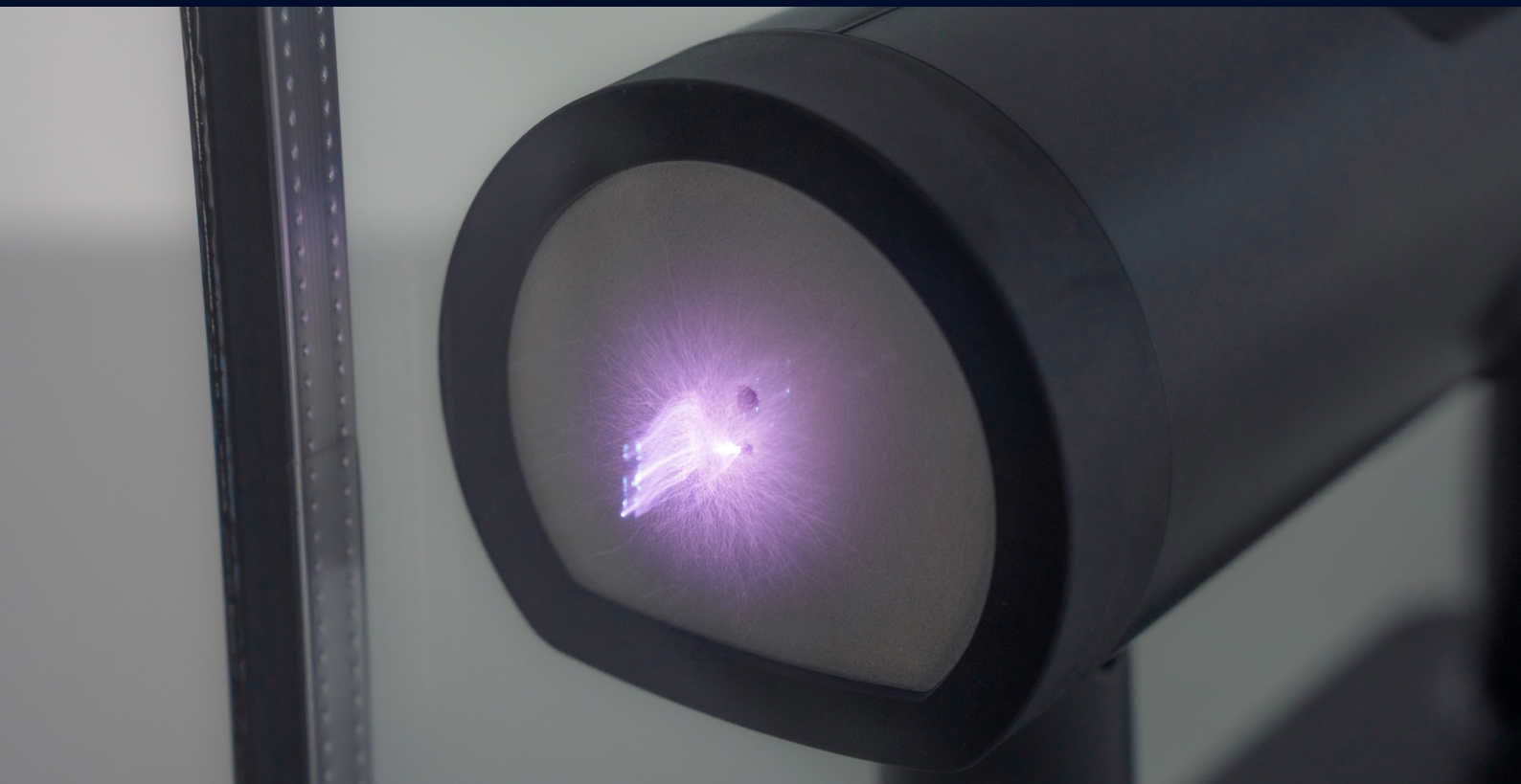

Table of contents

1. Warnings	3
2. Delivered with the device	4
3. Device overview	5
4. How Does It Work	6
5. Starting up for the first time	7
6. How to charge the battery	9
7. How to use Handheld Nova	10
8. Handheld Nova display	13
9. Measuring modes	16
10. Measuring settings	18
11. Storing the measurements	23
12. Errors and notifications when measuring	25
13. Factors to consider when taking a measurement	27
14. Restrictions	29
15. Web application	32
16. Calibration	33
17. Technical spesification	36

1. Warnings

- The instrument uses high voltage. The instrument should never be used near computers or other sensitive electronic devices.
- The instrument must only be used when properly positioned against an insulating glass unit. Never trigger the device in air or without contact with the glass surface to avoid a small electric discharge (spark).
- Persons with heart conditions or who use pacemakers should not use this instrument.
- The high voltage discharge should never be directed at humans or at animals either directly or through a conductive material such as wires or metal structures.
- Sparklike Handheld Nova is designed to measure only inert gas combinations such as Argon, Krypton combined with natural Air (78% Nitrogen, 20,9% Oxygen, 0,9% Argon + <1% other natural Air components) located within insulating glass units.
- Sparklike Handheld Nova should never be used to measure any flammable substances or be used in any flammable environment. Also make sure the insulating glass unit does not contain any flammable substances. (As an example of such substances, Isopropanol, Alcohol, Acetone, Xylene, Thinner).
- The instrument should never be used in wet or in humid conditions.
- Never use the instrument while standing on unsteady surfaces.
- The instrument is a precision measuring instrument and should be handled accordingly. Handle with care!
- Make sure that the front optic of the device is not scratched or contaminated with dirt.
- Do not clean the front optics. Contact manufacturer before interfering with the front optics in any way. The calibrations might be void in case of interfering.
- The device is not waterproof. Do not clean nor let the device come in contact with liquids of any form. The outer shell of the device might be cleaned with a slightly moist tissue (not optics). Do not use any kind of cleaning substances other than those suggested by the manufacturer.
- Always turn off the power when the instrument is not in use.
- Keep fingers and other body parts clear of the high voltage area when in use. Do not keep the device connected to your PC or other electronic devices while performing measurements.
- Do not allow the battery to be discharged completely before recharging.
- Do not open Sparklike Handheld Nova casing. In such case, calibration is void and no safety guarantee can be granted.
- Do not penetrate the casing with any metallic object or other objects.
- Do not use any other battery charger than the charger provided by the manufacturer.
- Do not charge the battery by any other means than with the charger provided.
- Do not use any other power source for Sparklike Handheld Nova than the battery provided.

2. Delivered with the device

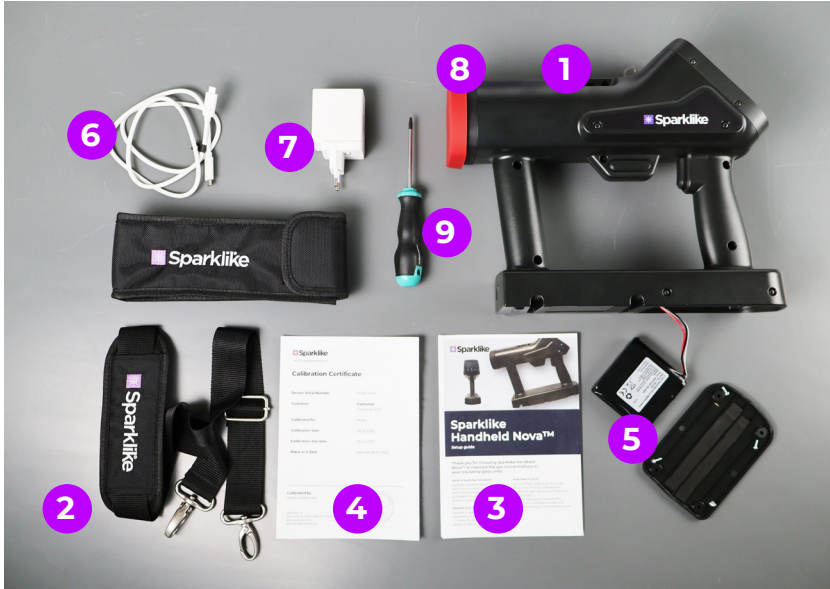

1. Sparklike Handheld Nova
2. Neck strap
3. Set-up guide
4. Calibration certification
5. Battery
6. USB-C Cable
7. Battery charger
8. Protective cap
9. TX10 screwdriver
10. Carry case

+ Instruction manuals can be downloaded at sparklike.com/en/hh



3. Device overview

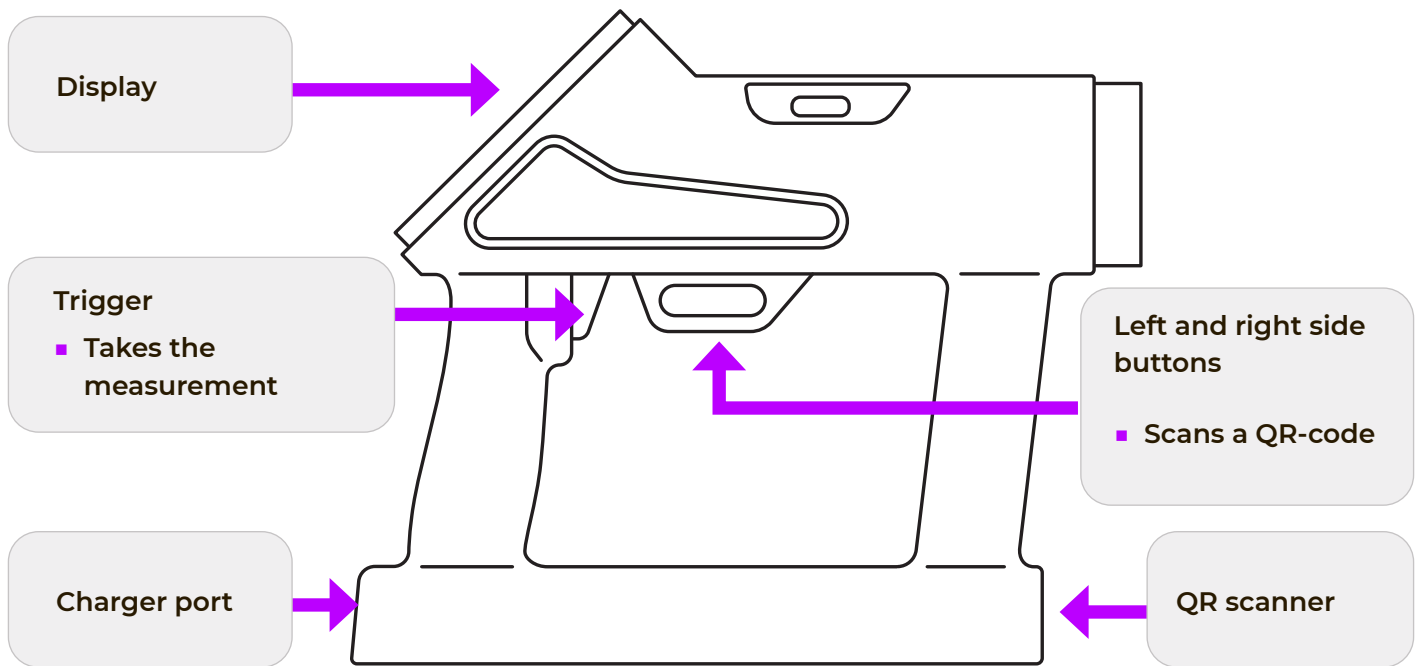

Front panel and display

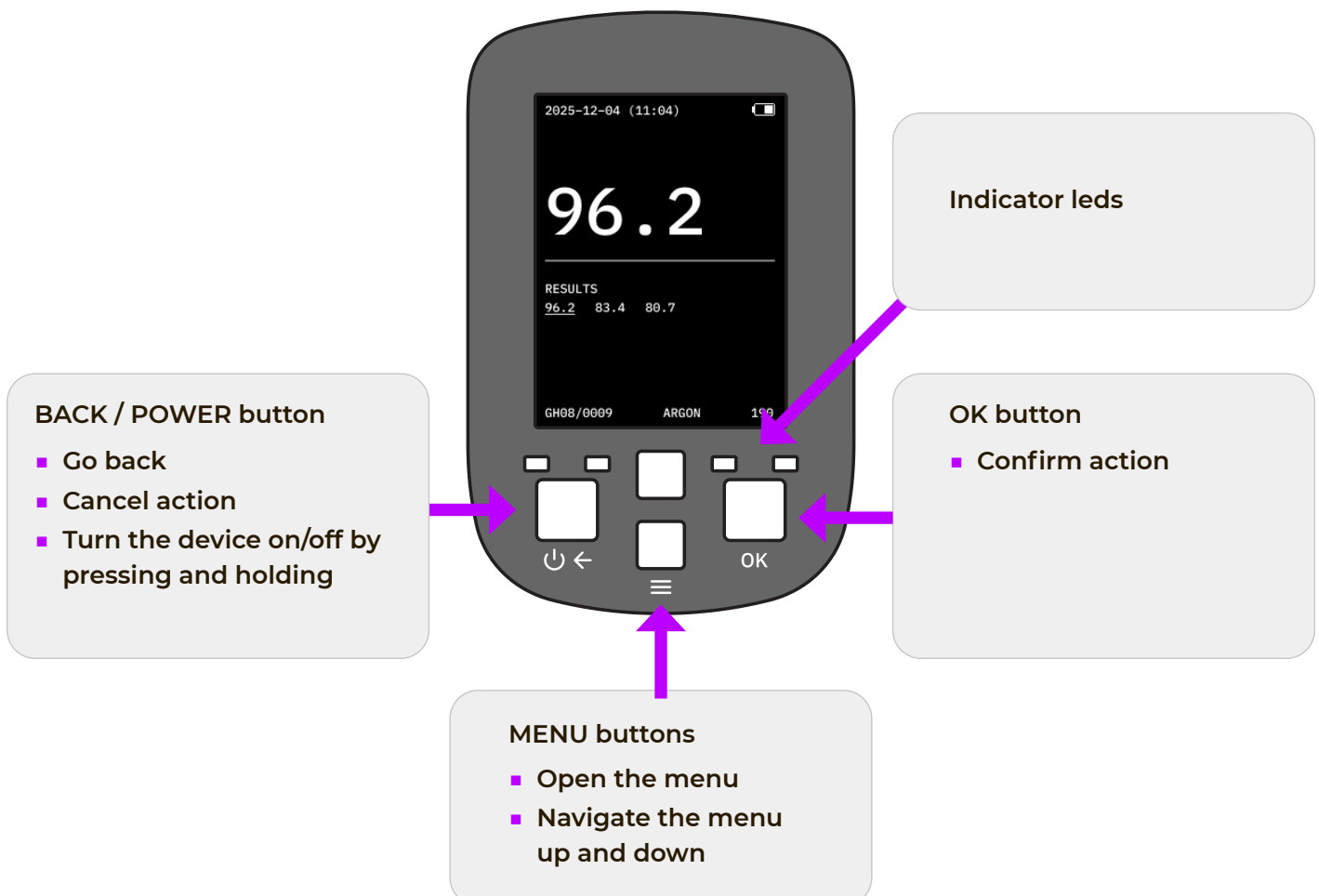

4. How Does It Work

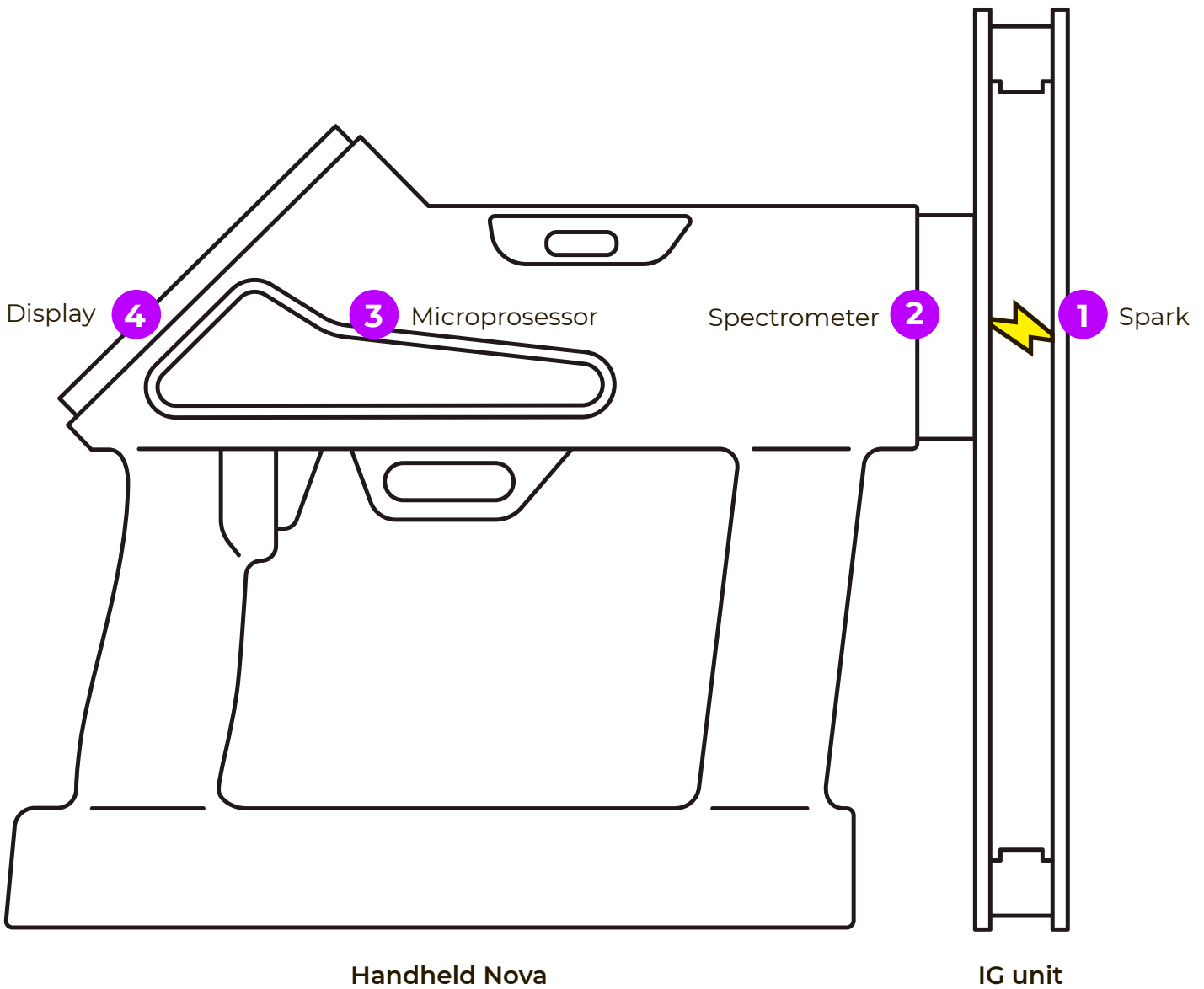

When you take a measurement

- 1 A high voltage spark is ignited inside the the insulating glass (IG) unit.
- 2 This high voltage spark causes argon atoms emit light to the spectrometer.
- 3 The microprocessor interprets the information of the spectrometer and calculates the argon concentration.
- 4 The result is shown on the display.

5. Starting up for the first time

5.1 Before powering up



1. Before powering up Sparklike Handheld Nova, charge the battery with the battery charger provided with the device.
2. Power up the device by pressing and holding the BACK/POWER button until the green LED lights up..

5.2 First start-up

At your first start-up, you'll be greeted with the activation code screen. To activate the device, you'll need to enter your personal activation code. You can get the activation code from the website sparklike.com/en/register-your-device/

1. Go to sparklike.com/en/register-your-device
2. Enter your personal information and the Handheld device's serial number
3. After pressing the confirm button, you'll get your personal activation code.
4. Enter the activation code in your handheld device.
5. When the code is inserted, press OK and the device is now activated and ready to use.



The serial number is shown in the Handheld device screen.

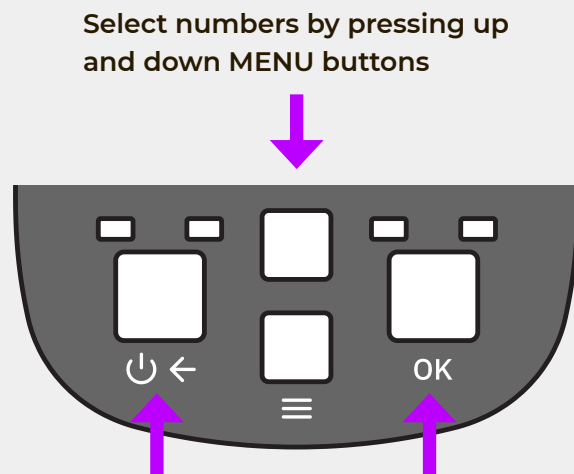

If you need to go back to previous number, press the BACK button.

Confirm by pressing OK

6. How to charge the battery

Sparklike Handheld Nova uses a Li-ion battery as the main power supply. The battery can only be charged when connected to Sparklike Handheld Nova.

The device is also provided with an integrated backup battery that enables Sparklike Handheld Nova to contain all data stored and maintain a current time and date even if the main battery runs out.

Sparklike Handheld Nova battery is designed so that it will be possible to perform measurements for approximately 16 hours before the battery runs out. This is naturally dependent on the frequency of use. The charging time for an empty battery is approximately 2 hours.

Measurement is not possible while charging or charger is connected.

1. Connect the provided charger to Sparklike Handheld Nova. Use only the USB-C charger supplied with the device. If the device was off, it will now start.
2. The battery icon on screen will have lighting icon on it to indicate charging.
3. The charge time is approximately 2 hours.
4. When charging is ready, this is indicated on the screen.

NOTE

Use **ONLY** the battery charger provided by the manufacturer. If any other charger is used, it may cause the battery to explode.

NOTE

Device itself has a much longer lifecycle than the Li-Ion battery pack. For this reason, it might be that the user or service must replace the battery after some years.

7. How to use Handheld Nova

7.1 How to perform a measurement

1. Make sure that the the insulating glass (IG) unit is positioned upright.
2. Point the Handheld Nova towards the IG Unit and press the barrel against the glass.
3. Hold the device still and pull the trigger. Don't tilt or move the device.
4. You'll hear a small spark go off and the measurement result will appear on the display.

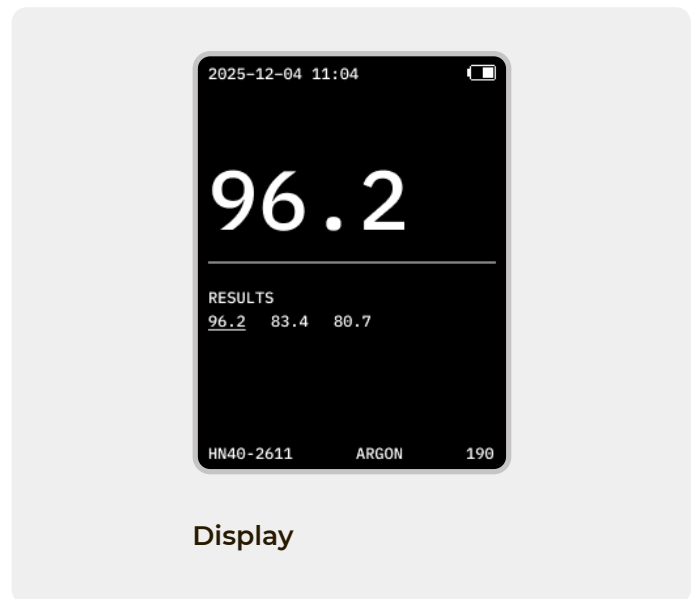
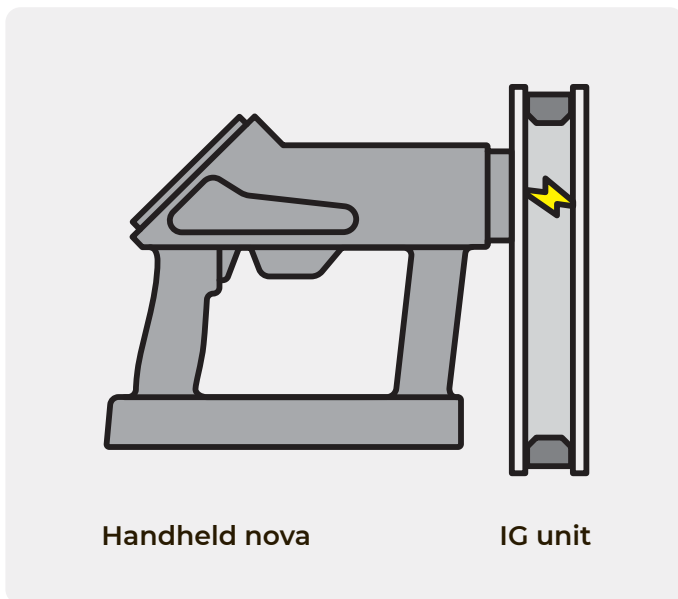

7.2 Things to keep in mind when measuring

Measure close to the spacer

As the spacer bar of an IG unit is often metallic or contains metal, the spacer bar will help the spark to ignite. It is therefore suggested that the measurement is made close to the spacer.

The center of Sparklike Handheld Nova should be approximately 5cm (2 inches) from the inner side of the spacer (Approx. 10mm from the side of the front piece). There is no difference at which height of the IG unit is measured.

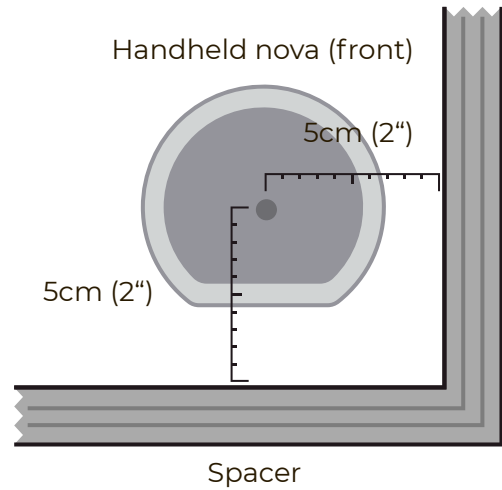

Keep the IG upright

Due to the Earth's magnetic field and the ionization of the gases, the spark will try to "travel up" during the measurement. This causes the spark to act more erratically than if the IG were lying flat down.

In this way the Low-E is protected better from burning, so it is suggested to measure the IG standing up.



Do not move the device during a measurement

During one measurement cycle two individual measurements are being made; one background measurement and one with the spark on.

If the hand unit is being moved during the measurement cycle, the background is altered and the results may not be accurate.



Keep the device straight to the IG unit

If there is space between the spark electrode and the surface of the glass, a big part of the spark burst will occur outside of the IG unit.

This means that the instrument is not measuring the spark inside the window, but a mix of the inside gas and normal air causing the readings to be too low. The user can easily hear when the hand unit is flushed to the IG.



Non Low-E IG units require grounding

As the Low-E coating is metallic, this will act as ground for the spark. This grounding is used when the instrument is calibrated.

If the window has no Low-E coating, there is no ground where the spark will ignite producing more erratic readings. These windows should be measured with either a finger on the back of the IG or some other metallic ground for the spark.

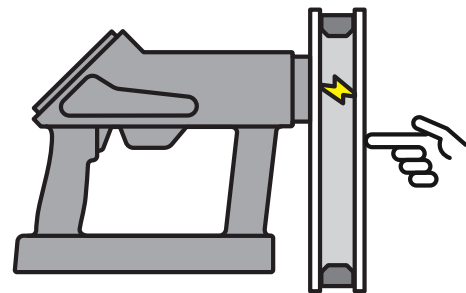

Measure several times

When measuring the spark will ignite inside the air space, ionizing the gases, leaving the gases ionized for a short period of time. This means that the second measurement will ignite more easily and produce a better result.

Measuring more than three times in one place may cause the Low-E coating to burn, changing the readout of Sparklike Handheld Nova. For repetitive measurements, move the hand unit slightly after two or three measurements.

Note

You can take several measurement samples and calculate the average in multi-sample mode. (See multi-sample mode)

8. Handheld Nova display

8.1 Start-up view

Start-up view appears when you power up the device. On this screen, you can see the device's serial number and calibration due date.

After a few seconds, the start-up view changes to the measurement view.

8.2 Calibration due date notification

Please note that to ensure accurate measurement, the device needs to be calibrated once a year.

When the calibration due date is approaching, the start-up screen prompts you to order a calibration. You can order a calibration via website sparklike.com/calibration. The QR code on the screen is a link to the website.

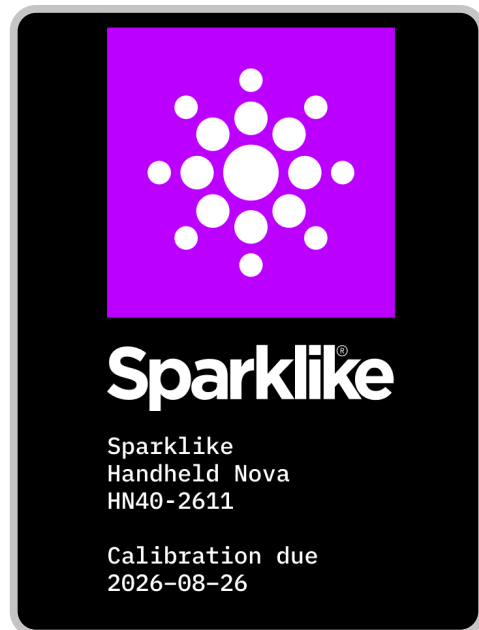

8.3 Measurement view

The measurement view is a the typical screen view of the device. Here you can see the results of your measurements and other information.

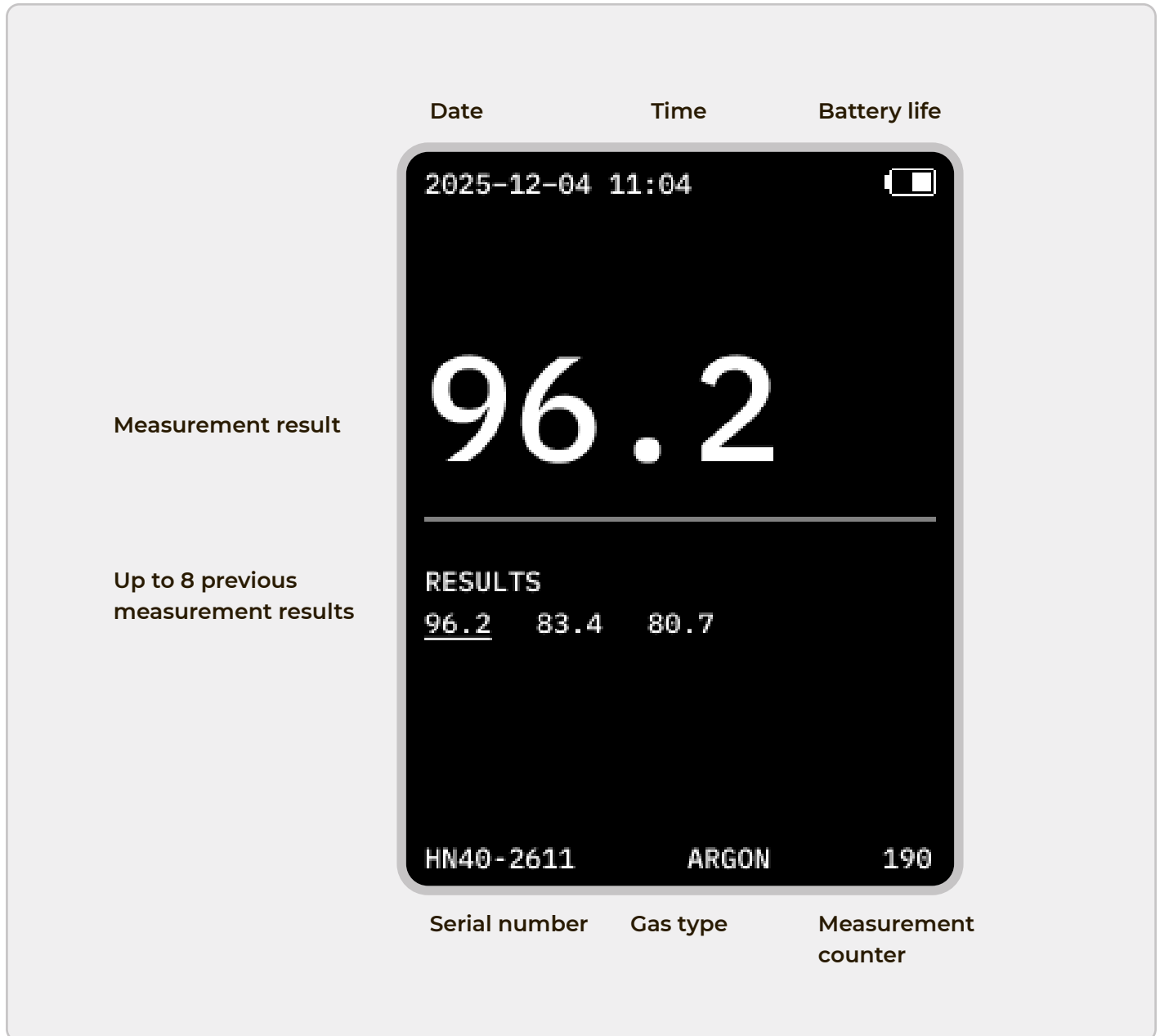

8.4 Device menu

The device menu is for changing the measurement settings.

- Open the menu by pressing the up or down MENU button.
- **Multi-sample** toggles between single and multi-sample measurements
- **Gas** toggles between argon and krypton gas. This option is only available if the device is calibrated for both gases.
- **High limits and low limits** define the approved percentage of gas in the IG unit. Measurements below or above the limit give a notification with measurement results.
- **Log** toggles the measurement logs on and off. If the log is turned on, Handheld Nova saves all the measurement data. The saved data can be viewed when the device is connected to the web application via BLE connection.
- Return to the measurement screen by performing a measurement or pressing the back-button.

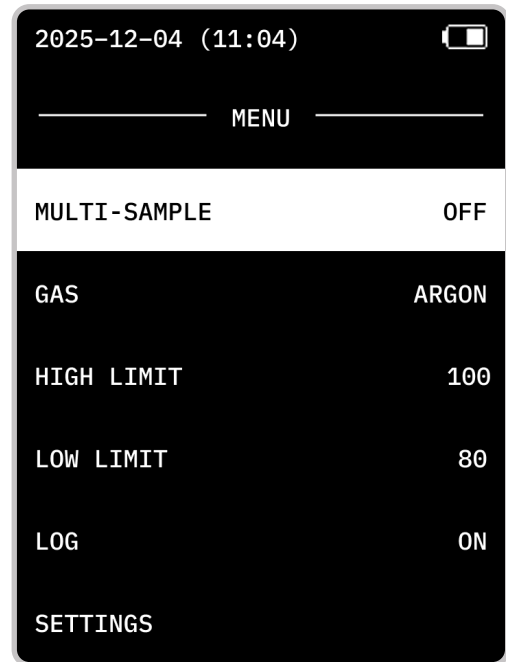

9. Measuring modes

9.1 Single measurement mode

This is the standard mode for taking measurements. You can take single measurements of an insulating glass (IG) units..

- After taking a measurement, the result is displayed in the upper part of the screen.
- Up to 8 previous results are shown in the lower part of the screen.
- If logging is ON, all the results are saved.
- To remove any previous measurements further back in the log, you must connect the device to the Web application. (See “How to use Web application”)

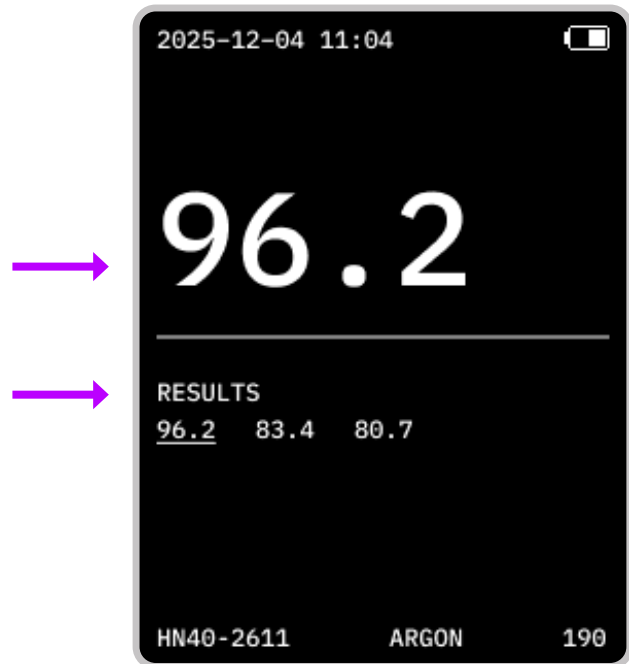

9.2 Multi-sample mode

In the multi-sample mode, you take several **measurement samples** of the IG Unit and calculate the average of the samples.

- The upper part of the screen shows the Average of the samples you took.
- The lower half shows the samples of which the average is calculated. The first sample on the left is the latest measurement.
- When you've taken enough samples, press OK to move on to the next measurement. This will reset the average.
- With larger IG units, it's good idea to take samples from the different parts of the glass.
- Problematic measurements are marked with 'ERROR' and they are not taken into account when the average value is calculated.

NOTE

You can take as many samples as you like, but only eight of the latest are shown on the display.

NOTE

Take average measures only from single IG units. To check the average concentration of several different IG units, connect the device to the web application. (See web application)

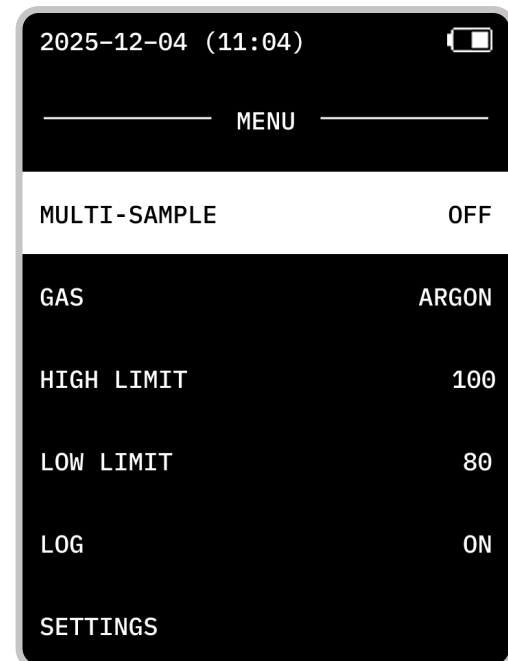
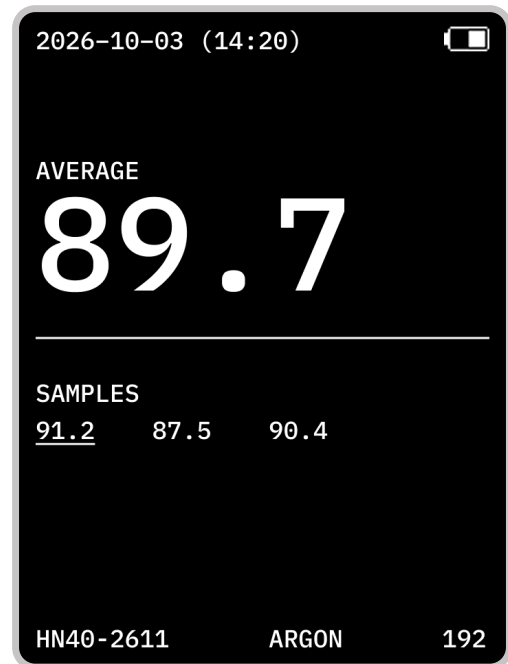

10. Measuring settings

10.1 Changing the gas type

If your Handheld Nova is calibrated for both argon and krypton gas, you can change the gas you want to measure.

If your device is only calibrated for argon gas, then it's not possible to change to krypton gas.

To change the Gas type

1. Open the Menu and select Gas.
2. Press OK toggle between argon and krypton.

The selected gas will always be shown on the bottom of the display.

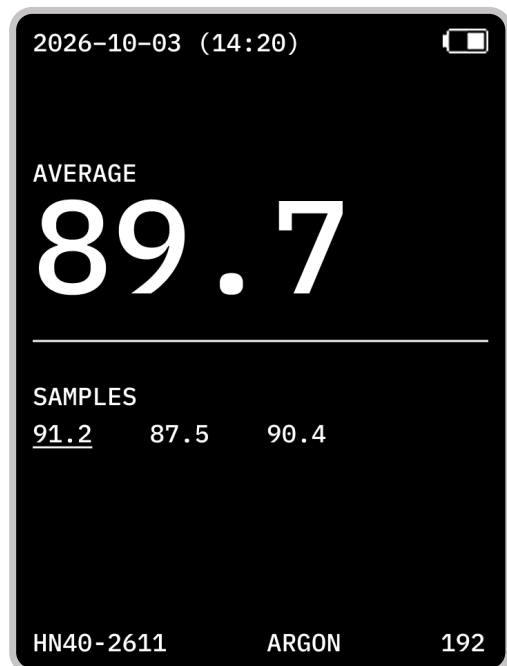
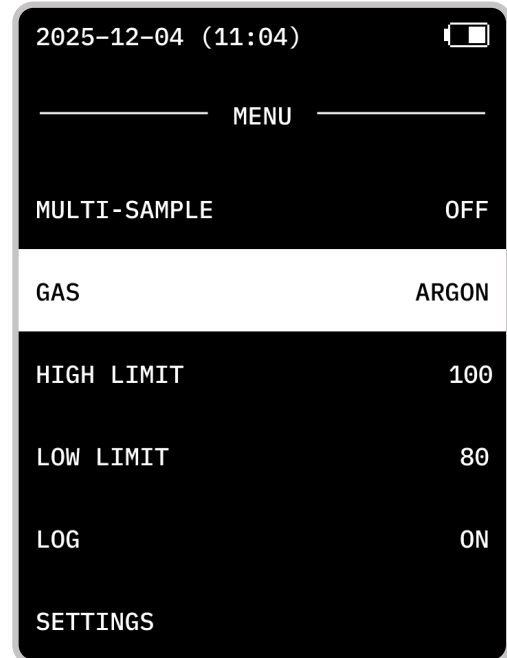

10.2 High and low limits

You can set high and low limits of gas concentration. The Handheld Nova will notify you if the measurement result is above or below the set limit.

Notifications are shown next to the latest result.

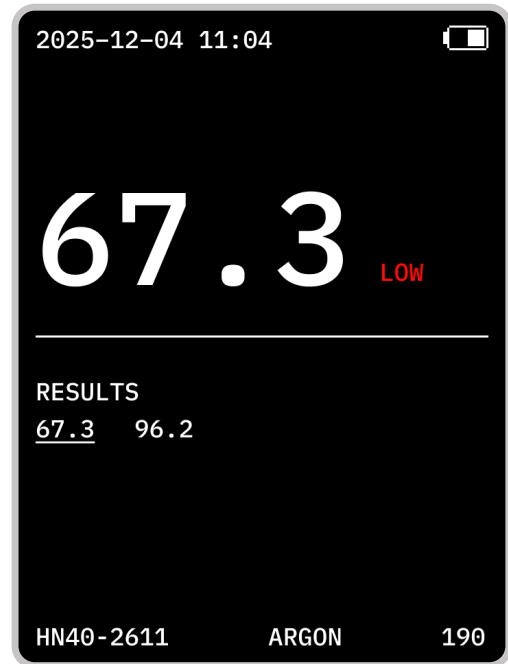

To adjust the limits

1. Open the menu by pressing the MENU button.
2. Select High limit or Low limit and press OK.
3. Increase or reduce the limit by pressing up and down the MENU buttons.
4. Press OK again to confirm changes, or BACK to cancel.

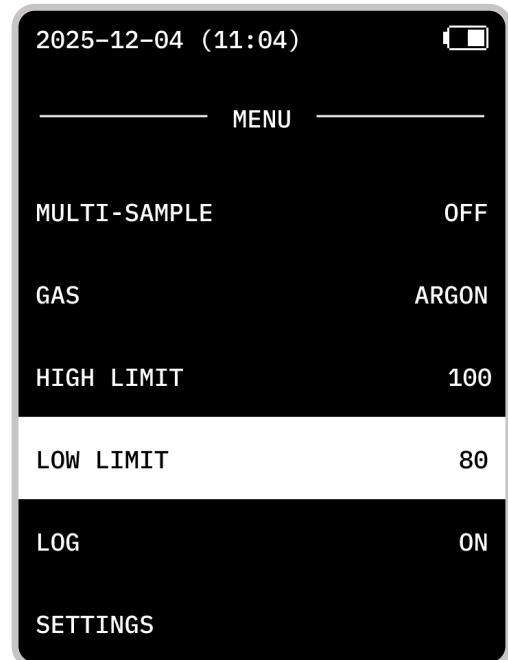

NOTE

The measurement limits are used to notify you if the gas concentration is above or below the desired level. You can quickly see when the limits are exceeded.

10.3 Log

When the measurement log is on, all the measurement data is saved in the device's memory.

1. Open the menu.
2. Select log and press OK.

This will toggle the logging on and off. When the logging is on, you see a red **recording icon** on the display's upper left corner.

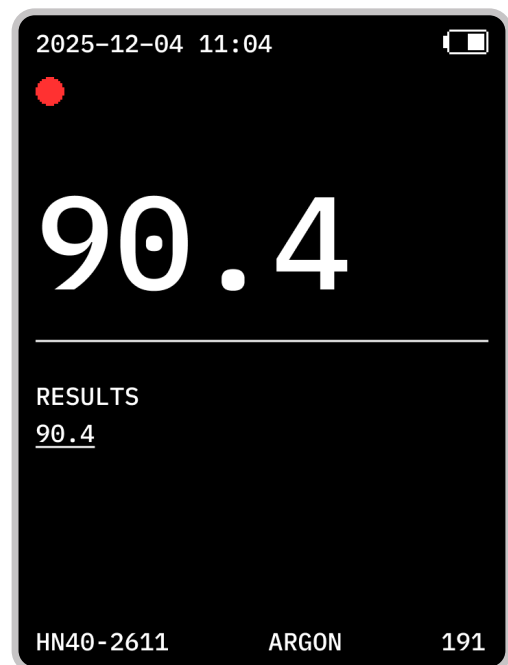
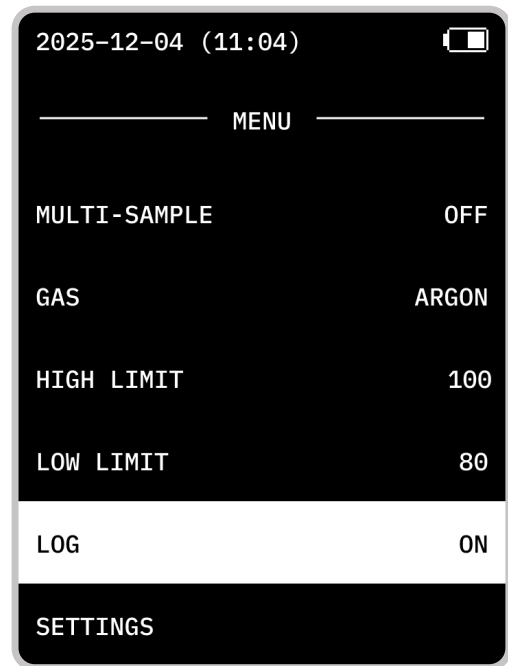

10.4 Device settings

- **Time:** Setting is for changing the device's time. Time is shown in a 24-hour format.
- **Date:** Setting is for changing the device's current date. The date format is Year-month-day.
- **BLE Connection:** Connect to a web application via desktop PC. You can turn this on or off.
- **Reset Log:** You can erase all logged measurements stored in a device.

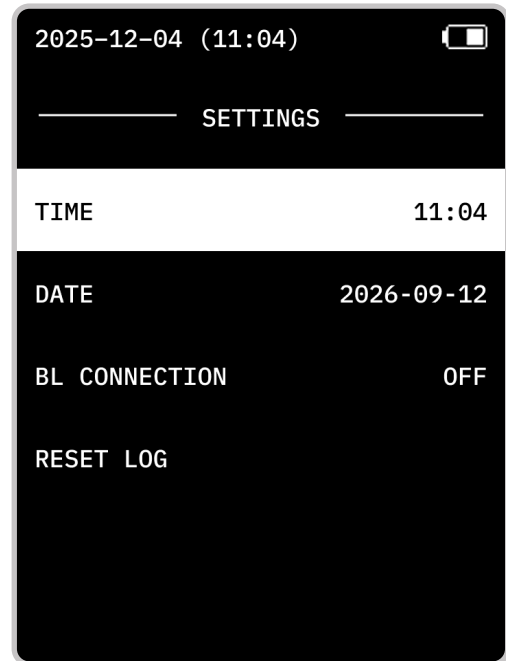

10.5 Changing the time and date

1. Open the menu
2. Using the MENU buttons, select settings and press OK.
3. Select the time or date and press OK.
4. Change the value with up and down MENU buttons
5. Confirm the value by pressing OK or cancel by pressing BACK



NOTE

Connecting the device to the web application always syncs the time with your PC.

10.6 Sleep mode

Without activity, the display will go off after few minutes to conserve battery. The green LED indicates power being on. After one hour the device will automatically turn OFF.

10.7 Turning the device on / off

You can turn the device on and off by pressing and holding the BACK button until the green LED turns on.

To turn off the device, keep left button pressed until the green LED turns off. The device will perform safe shutdown after this.

- If the device does not start after pressing the button for 10 seconds, the battery might be empty and require charging.
- If the device becomes unresponsive and cannot be turned off, press DOWN and OK buttons at the same time to force power off. In normal operation this should not be used, as it bypasses the safe shutdown and may corrupt measurement data storage.

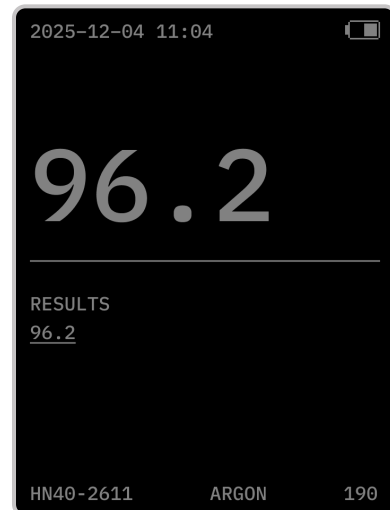

Display in energy saving mode

11. Storing the measurements

Sparklike Handheld Nova can store over 30.000 measurements, i.e. more than 1 month at 1000 measurements per day.

If the measurement log is on, then all the measurement data is saved in the device's memory.

You can turn the log on and off by opening the menu. Then select the log and press OK. This will toggle the logging on and off.

11.1 Removing individual results from the log

In multisample mode, you can reject the latest sample by pressing the BACK button immediately after the measurement.

The rejected sample is excluded from the multisample average. In single measurement mode, pressing BACK returns to the measurement screen.

To remove previous measurements further back in the log, you must connect the Handheld Nova to the Web application. (See "How to use Web application")

11.2 Erasing all log results

You can reset the log from the settings menu. Please note that this action is irreversible.

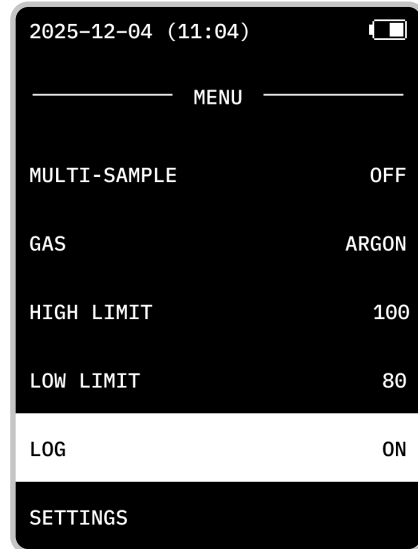

NOTE

time and date must be set for meaningful logging

Measurement data entries include:

- Measurent result
- Time and date
- Possible errors and limit notifications
- Optional QR/barcode information

11.3 Scanning a barcode

Some IG units have a barcode that contains information such as IG unit's type, serial number or other information related to traceability.

You can add this information to the measurement result by scanning the barcode with Handheld Nova's barcode reader before measurement.

1. To scan a barcode, press the left or right side-button. This will activate the barcode scanner for a few seconds.
2. Direct the scanner light to the barcode and hold still.
3. When the barcode is scanned, the light turns off and the barcode information tag appears on the screen.
4. The tag will be added to all subsequent measurement results.
5. If you want to change to another tag, press the side button again and scan the next barcode.
6. If you want to turn the tag off, press the side button and direct the scanner light to the ground. When the scanner finds nothing to scan, the previous tag will be turned off.

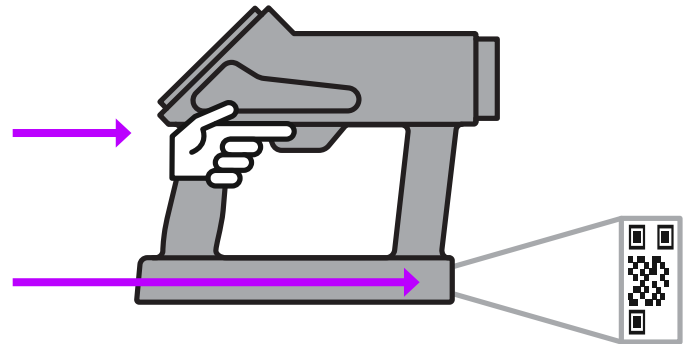

List of supported barcodes:

- Code 128
- QR Code
- Data Matrix

Please ask Sparklike about additional code types

12. Errors and notifications when measuring

There are several factors that can affect the measurement. When these factors occur, an error or warning message will be shown on the screen.

12.1 Error messages

Weak spark signal

The detector cannot see the spark well enough to make a measurement. Check that the spark hits through the window. Try measuring from a slightly different position.

Bad spark

Gas percentage cannot be calculated from the spectrum measured. Typically, this error message is given when the spark ignites outside the window.

Overexposure

The sensor receives too much light during measurement. Check that there are no bright lights behind the window being measured.

No spark detected

The sensor does not receive enough light from the spark. Check that spark hits through the window. If the spark hits the side spacer, try measuring from a slightly different location so that the spark travels through the window. Check also that the sensor 'eye' in the front piece is clean of dust and dirt.

Error

An unknown error occurred in the measurement. Try repeating the measurement. If the problem persists, contact your representative.

12.2 Notification messages

High

The measurement is above the set limit. See “high and low limits”.

Low

The measurement is below the set limit. See “High and low limits”.

12.3 Warning messages

Low concentration

The gas concentration was too low to be measured.

Bad angle

The device was off the required 90-degree angle to the IG Unit.

Weak spark

The sensor does not receive enough signals. Try measuring again. If the problem persists, there may be an electronics fault that requires service.

12.4 Forced Shutdown

If the device or its software becomes unresponsive, the device can be forced to power off.

To perform a forced shutdown, press and hold the **OK** and **Down menu** buttons simultaneously. This will cut power even if the software is not responding.

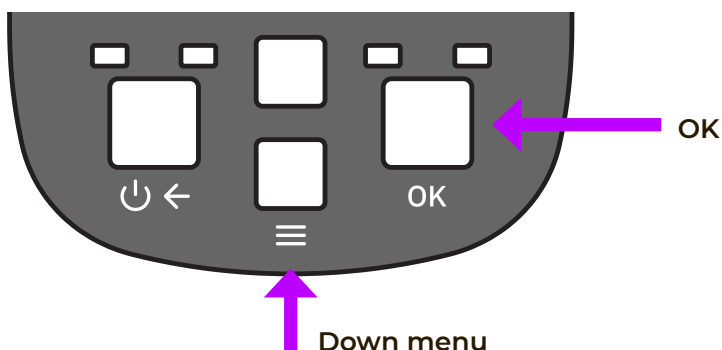

NOTE

The charger must be disconnected before performing a forced shutdown. If the charger is connected, it will keep the device powered on and the shutdown cannot be completed.

13. Factors to consider when taking a measurement

To be able to use the instrument in the best way, there are some factors influencing the measurement that should be considered. Sparklike Handheld Nova requires two main things; Light (Optics) and High Voltage (Electricity).

If either or both factors are disturbed, the measurement might be affected.

13.1 High voltage

The measurement is made using a high voltage spark. The voltage is approx. 50 000 V, but the current is very small. Coming into contact with the spark will sting a little but not harm a normal healthy person even though the instrument MAY NOT to be used by a person with a pacemaker or who is in poor physical health. Nor should the spark ever be pointed at any sensitive areas (eyes etc.).

When measuring, the hand unit will create a spark that passes through Glass 1 and ignites inside the air space. Glass is an electrically insulating material, as is air. This means that the spark needs to be strong enough to jump into the air gap. In addition to the other electrically insulated materials, such as laminated glass, plastic films, etc. on either side of Glass 1, this makes it even harder to ignite inside the IG.

If there is a metallic coating on Glass 1, it will be impossible for the spark to get through as the metallic film will cause the spark to stay on the surface. Argon gas is a better conductor for the spark than air. This means that the spark ignites easier when the fill level is higher. The other thing that helps the spark “jump” is a metallic coating on Glass2, which grounds the spark.

13.2 Light

The measurement is dependent on a stable light signal. The light cannot be measured if the total light level is too weak or too strong. The total light intensity increases with the background light level as well as with increasing argon percent when measured.

If the background light is too strong, e.g., measuring against the sun or a bright lamp, the argon light will “drown” in the sunlight. If the argon concentration is very low, the signal light is very low, causing the spectrometer not to see the light.

Note

If you get the error message “NO SPARK DETECTED”, check that spark hits through the window.

13.3 Factors to consider when measuring

FACTORS AFFECTING THE OPTICS

- Colored glass
- Tinted glass (minimal effect)
- Strong background light measurement (against the sun or other source)
- Dirt on the glass (minimal effect)
- Dirt on the front optical fiber
- Mistreated front optical fiber or electrode

FACTORS MAKING IT EASIER FOR THE SPARK TO “JUMP”

- High argon fills
- Thin glass (6mm or less)
- Thin air space (20mm or less)
- Metallic or another conductor on surface 3, such as low-e coating
- Metallic spacer bar

FACTORS AFFECTING THE SPARK

- Thick glass (over 6 mm)
- Plastic films on glass 1 (laminated glass, coatings, etc.)
- Metallic films on glass 1
- Metallic components in glass 1
- Low Argon fill (less than 90%)
- Wide spacer (over 15mm)
- Electrode is not in contact with the glass surface
- Sparklike Handheld Nova is not evenly pressed against the glass
- Non-metallic spacers

CORRECT CONDITIONS

- Preferably upright standing glass unit
- Stable dark background light
- The device NOT moved during measurement

14. Restrictions

The following is a list of different IG types that can be measured and types that cannot or are difficult to measure. There are several conditions that will affect the restrictions.

Most of the restrictions are about how the spark breaks through the glass and comes in contact with the center gas. Any metallic coating (on the side of measurement) will prevent the spark from reaching the gas.

A thick glass or a thick lamination will also restrict the spark from going through the element. As Argon and Krypton are good conductors, a high fill level (>80%) will make the process easier. Consult your local distributor or Sparklike for any special types.

Note

Most of the restrictions are caused by the Glass 1

14.1 List of different IG types that can be measured

A IG with glass 1 = clear and surface 3 = LowE

Surface 1	Glass1	Surface 2	Spacer	Surface 3	Glass 2	Surface 4
Clear	Clear max. 6mm	Clear	max. 24mm	LowE	N/A	N/A

B IG with glass 1 = Clear and surface 3 = Clear

Surface 1	Glass1	Surface 2	Spacer	Surface 3	Glass 2	Surface 4
Clear	Clear max. 6mm	Clear	Max. 24mm	Clear	Clear max. 6mm	N/A

C IG with glass 1 = Toughened and surface 3 = LowE

Surface 1	Glass1	Surface 2	Spacer	Surface 3	Glass 2	Surface 4
Clear 6mm	Tgh Max	Clear	Max. 24mm	LowE	N/A	N/A

D IG with glass 1 = Toughened and surface 3 = Clear

Surface 1	Glass1	Surface 2	Spacer	Surface 3	Glass 2	Surface 4
Clear 6mm	Tgh Max 6mm	Clear	Max. 24mm	Clear	Clear max 6mm	Clear

14.2 List of different IG types that are difficult or unable to measure

E IG with glass 1 = Tinted

As there are a lot of variations of tinted glass including solar control and different colorizations of the glass, there cannot be one true rule for this.

If the tint includes a metal component, it will prevent the spark from breaking through glass 1 and it will therefore prevent the measurement. As the Handheld measures light wavelengths, a colored glass might also have an effect.

Please contact your distributor for these. Otherwise, rules apply as point A.

F IG with glass 1 = Laminated

As the lamination will act as an insulator, it will therefore more efficiently prevent the spark from breaking through glass 1. Therefore, there might be difficulties measuring thick laminations.

As the Argon and Krypton gas will act as conductors, they will therefore make the process easier. In an IG unit where the Argon/ Krypton concentration exceeds (>) 85% gas the following general limits can be set.

Surface 1	Glass1	Surface 2	Spacer	Surface 3	Glass 2	Surface 4
Clear	4+1+4 Laminated	Clear	Max. 20mm	LowE	N/A	N/A

G IG with glass 1 = Frosted

Same restrictions as for a. and b. depending on LowE coating

H Triple glazing

Due to different compositions of a triple glazing unit there are several that can not be measured as the spark will not reach the insulating gas.

As one guideline can be mentioned that if Surface 3 or 4 has an LowE coating and there are no one of the restrictions mentioned earlier, the unit can be measured, otherwise contact your distributor or Sparklike.

15. Web application

15.1 How to connect to your computer

To connect Handheld Nova to a computer, you need to have a computer and web browser that support BLE. Note that not all browsers support BLE.

Handheld Nova

1. Open the menu by pressing the MENU button on your Handheld Nova.
2. Select Settings and press OK
3. In settings, select BLE Connection and make sure the BLE functionality is turned on..

Windows PC

1. Make sure the Bluetooth is turned on in Windows
2. Open Sparklike Nova application at nova.sparklike.com
3. Click 'Connect' on the right corner
4. Select your device from the dialog and click PAIR / CONNECT.

15.2 How to use the web application

See separate guide on how to use the web application to download and analyze measurement data. The application is available at nova.sparklike.com

16. Calibration

To ensure reliable and accurate measurements, Sparklike Handheld™ Nova must be calibrated annually.

Regular calibration verifies that the instrument measures gas concentration within specified accuracy limits and compensates for normal component aging and environmental influences.

Calibration for Sparklike Handheld™ Nova is performed at Sparklike headquarters in Helsinki, Finland, and at authorized Sparklike Calibration and Service Centers.

To order calibration and/or maintenance, please visit:

sparklike.com/en/order-calibration

Sparklike Authorized Calibration and Service Centers for Sparklike Handheld™ Nova:

- North America by GED Integrated Solutions
- Australia, New Zealand, and Southeast Asia by Elegant I.G.
- Poland, Latvia, and Lithuania by Polver
- UK and Ireland by Inagas
- Germany, Austria, and Switzerland by Helantec GmbH
- South Korea by T&T Co.,Ltd
- China by Sparklike China

Proper annual calibration is essential for maintaining measurement accuracy and ensuring reliable insulating glass quality control.

16.1 Packing and Shipping for Calibration

Sparklike Handheld™ Nova is a precision measuring instrument and must be packed carefully for transportation. Improper packing may cause damage to sensitive components and affect measurement accuracy.

Always use the original transportation case supplied with the device. Ensure that the instrument is firmly supported inside the case and that it cannot move during transport. All accessories must be packed securely in their designated compartments.

- Before shipping, switch off the device.
- If you no longer have the original transportation case, please contact Sparklike Service for instructions before shipping the device.
- Careful packing is essential to prevent damage during transportation and to ensure safe and efficient service handling.

17. Technical spesification

Overall Dimensions	310 × 100 × 270 mm (length × width × height)
Measurement time	About 2 seconds
Min/max glass thickness IGU	2 – 8 (up to 12) mm *
Min/max cavity dimension	6 – 14 (up to 20) mm *
Measurement range	50–100 % Ar
Weight	Device 1.7 kg, Hard case 1,5 kg
Operating temperature	+5 to +35 °C
Humidity	10–90%
Battery Charger	45W USB-C charger (15V, 2.5A min)
Connectors	USB-C charging port
Connectivity	2.4 GHz, compatible with standardized wireless protocols
Display	240x320 Pixel LCD display
Software	Proprietary Sparklike Software
Data logging capability	30 000 measurements
Barcode / QR reader focus distance	150 mm
Barcode types supported	Code 128. QR Code, Data Matrix
Li-ion battery Capacity	Li-Ion, 50.4 Wh, 14.8V. 2000 measurements.

*** Subject to IGU construction**

Calibration interval for the specified accuracy is max. 12 months

EU declaration of conformity

1. Radio equipment (product, type, batch or serial number):

Product name: Sparklike Handheld Nova
Type/Model: Handheld 4.0
Serial number: HN40-xxxxx

2. Name and address of the manufacturer:

Sparklike oy
Osmontie 34
00610 Helsinki
Finland

3. This declaration of conformity is issued under the sole responsibility of the manufacturer.

4. Object of the declaration (identification of the radio equipment allowing traceability):

Industrial measurement device with 2.4 GHz BLE radio.
Operating band: 2402–2480 MHz
Max RF output power: 10 mW EIRP
Rated input: USB-C 15 V – 2.5 A

5. The object of the declaration described above is in conformity with the relevant Union harmonisation legislation:

Directive 2014/53/EU (Radio Equipment Directive)
Directive 2014/35/EU (Low Voltage Directive)

6. References to the relevant harmonised standards used or references to the other technical specifications in relation to which conformity is declared:

Radio (spectrum):
- ETSI EN 300 328 V2.2.
- ETSI EN 301 489 – 1 V2.2.3
- ETSI EN 301 489 – 17 V3.3.1

7. Notified Body:

Not applicable (internal production control).

8. Signed for and on behalf of:

Place and date of issue: Helsinki, Finland,
2026-03-30

Name, function: Pekka Lehtinen, Service manager

Signature: _____



This device complies with Part 15 of the FCC Rules. Operation is subject to the following two conditions:

1. This device may not cause harmful interference, and
2. This device must accept any interference received, including interference that may cause undesired operation. (47 CFR §15.19)

Note (Class A):

This equipment complies with the limits for a Class A digital device under Part 15 of the FCC Rules.

These limits are intended to provide reasonable protection against harmful interference when operated in a commercial environment.

The equipment generates, uses, and can radiate RF energy and, if not installed and used in accordance with the instructions, may cause harmful interference to radio communications. (47 CFR §15.105)

Changes or modifications not expressly approved by the party responsible for compliance could void the user's authority to operate the equipment. (47 CFR §15.21)

Contains FCC ID: X8WB BT40F

Canada

Contains IC ID 4100A-BT40F (Canada)

United States (FCC) — Supplier's Declaration of Conformity (SDoC)

Product: Sparklike Handheld Nova

Model: Handheld 4.0

FCC Compliance Statement (47 CFR §2.1077)

This device complies with Part 15 of the FCC Rules.

Contains FCC ID X8WBT40F (USA)

Responsible Party (U.S. Contact)

[US Responsible Party Legal Name]

[Street Address]

[City, State ZIP], USA

Phone: [+1 ...]

Email: [..]

Part 15 Operating Conditions (47 CFR §15.19)

This device complies with Part 15 of the FCC Rules. Operation is subject to the following two conditions:

- (1) This device may not cause harmful interference, and
- (2) this device must accept any interference received, including interference that may cause undesired operation.

Class A digital device notice (47 CFR §15.105)

NOTE: This equipment has been tested and found to comply with the limits for a Class A digital device, pursuant to Part 15 of the FCC Rules.



Scan the QR-code for further instructions and support

→ sparklike.com/guidance/hh

Contact us

service@sparklike.com

Sparklike Oy, Helsinki, Finland

Contact your local distributor

→ Sparklike.com/en/contact-us